

Name: _____

Student number: _____

2nd Re-Exam 2, Module 7, Study Unit 202001361 Languages & Machines
Tuesday, June 1, 2021, 18:15 - 20:15

This second exam of Module 7 consists of the **Languages & Machines part** only, and is a **2h exam**.

You are allowed to use a handwritten cheat sheet (A4, double sided) during the exam.

After you finished your exam, take pictures of all pages and upload them as **one PDF** to the canvas assignment for this exam.

If you intend to leave before 20:15, then quietly come with your exam to the front and take the pictures there. Otherwise, please wait for our announcement at the end of the exam.

1. (8 points) Consider the following NFA- λ , M (only q_3 is accepting):

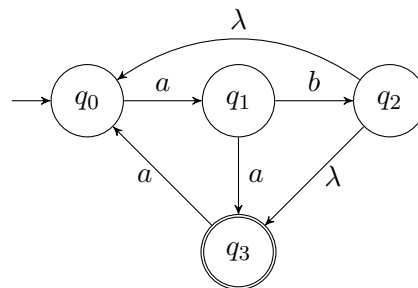

- (a) Does the automaton accept the word *aabaa*?

If yes, provide a sequence of states with which the automaton can accept the word.

If no, provide a sequence of states with which the automaton rejects the word. If the automaton rejects because there is no transition to a successor state with the according input, add "deadend" to the end of the sequence.

No. A potential rejecting state sequence is:

Yes. The sequence of states is:

Does the automaton accept the word *abab*?

If yes, provide a sequence of states with which the automaton can accept the word.

If no, provide a sequence of states with which the automaton rejects the word. If the automaton rejects because there is no transition to a successor state with the according input, add "deadend" to the end of the sequence.

No. A potential state rejecting sequence is:

Yes. The sequence of states is:

Name:

Student number:

- (b) Transform the automaton M step by step to a regular expression.
States must be eliminated in the order q_1, q_2 .

After elimination of q_1 :

After elimination of q_2

Thus, the regular expression obtained is:

Name: _____

Student number: _____

(c) Fill in the following table with the λ -closure and input-transition function of M .

	λ -closure	a	b
q_0			
q_1			
q_2			
q_3			

(d) The following incomplete DFA accepts the same language as M .

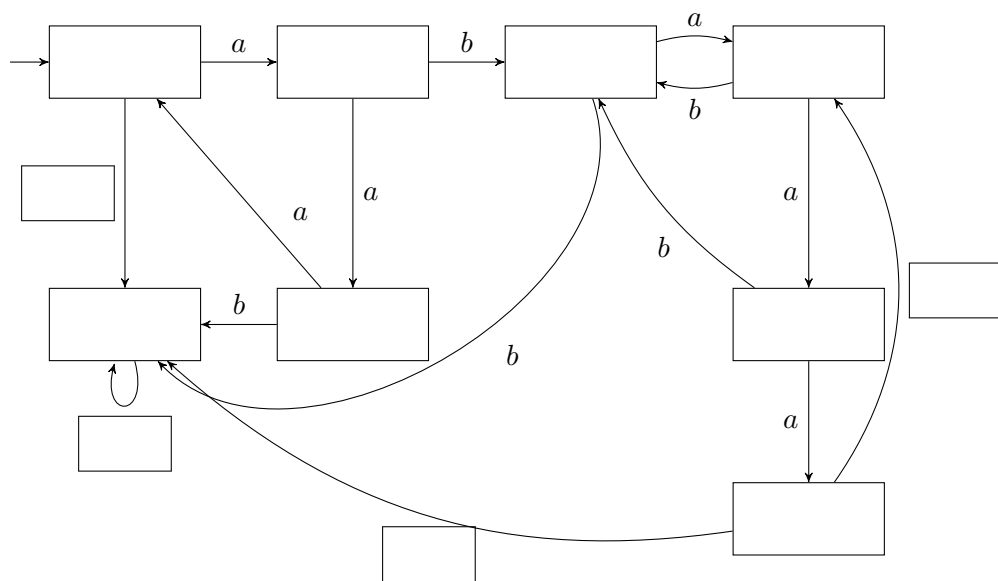

- i. Mark the accepting state/the accepting states.
- ii. Label the states with the set of λ -NFA states they represent.
- iii. Complete the white boxes at the transitions.

(e) Modify the λ -NFA in the figure below such that the word "a" is also in its language (but no further new words).

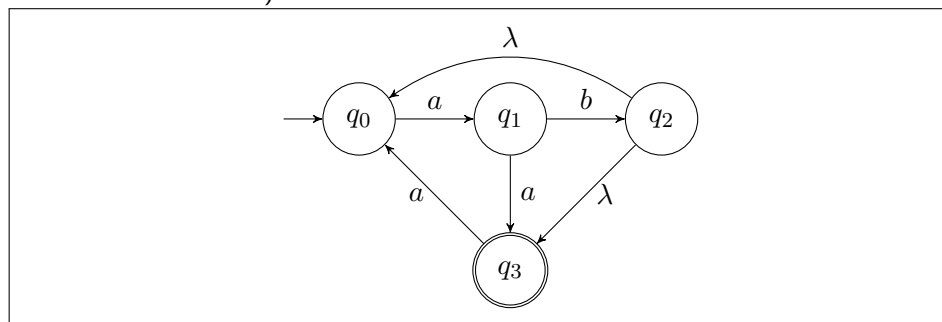

2. (8 points) For each of the following languages, indicate whether it is

- A: regular
- B: context-free but not regular
- C: recursive but not context-free
- D: recursively enumerable but not recursive
- E: not recursively enumerable

For each correct answer, you will get 1 point. For each incorrect answer, you will lose 1 point. For no answer, you get 0 points. The total points of this exercise will not become negative.

No further explanation is required.

- Language $L_1 := \{w \mid w \text{ encodes a Turing machine which writes sequence } abc \text{ for input } w\}$
- Language $L_2 := \mathcal{L}(a^*b^*) \cap \mathcal{L}(a^*c^*)$
- Language $L_3 := \{a^i b^j c^k \mid i \text{ even}, j \bmod 3 = 0\}$
- Language $L_4 := \{b^j c^{2i} b^j (cb)^i \mid 0 \leq i \leq 64 \text{ and } 0 \leq j \leq 3i\}$
- Language $L_5 := \{a^i b^j c^k \mid 0 \leq i \leq j \leq k\}$
- Language $L_6 := \{a^{i+2} c b^{i+4} \mid 0 \leq i\}$
- Language $L_7 := \{a^i b^j a^{4i} b^{7j} \mid i \geq 0, j \geq 0\}$
- Language $L_8 := \{w \mid w \text{ encodes a Turing machine which always writes the sequence } def\}$

3. (5 points) Consider the following languages

- $L_1 = \mathcal{L}(a^*b^*)$
- $L_2 = \mathcal{L}(c^*d^*)$
- $L_3 = \{w \in \{a, b\}^* \mid |w| = n^2 \text{ for some } n \geq 0\}$
- $L_4 = \{w \in \{a, b\}^* \mid |w| \bmod 3 = 0 \text{ and } |w| \bmod 2 \neq 0\}$

Which of the following languages are regular? Mark languages for which this is the case with Y and mark those for which this does not hold with N . Leave out the answer if you do not know. Correct answers yield 1 point, for incorrect answers you lose 1 point. For no answer, you get 0 points. In total, you cannot get less than 0 points for this question.

$L_2 \cap L_3$

$L_1 \cup L_4$

$L_2 \cup L_3$

$L_3 \cup L_4$

$\overline{L_4}$

4. (10 points) Consider the following context-free grammar G :

$$G = \begin{cases} S \rightarrow ABB \mid \lambda \mid AB \\ A \rightarrow Aaa \mid a \\ B \rightarrow Cab \\ C \rightarrow aC \mid a \end{cases}$$

(a) Complete following grammar G' in Chomsky Normal form such that it is equivalent to G .

$$G' = \begin{cases} S \rightarrow \boxed{} \mid \lambda \mid AB \\ D \rightarrow \boxed{} \\ A \rightarrow EF \mid a \\ \boxed{} \rightarrow AF \\ F \rightarrow \boxed{} \\ B \rightarrow \boxed{} \\ H \rightarrow FI \\ \boxed{} \rightarrow b \\ \boxed{} \rightarrow FC \mid \boxed{} \end{cases}$$

(b) Let $w = caab$. Use the table below to apply the CYK-algorithm (after Cocke-Younger-Kasami) to decide whether $w \in \mathcal{L}(G')$. In case of empty sets, explicitly write " \emptyset ".

	1	2	3	4
1				
2				
3				
4				

Name:

Student number:

Use the results of the CYK-algorithm to provide a derivation tree of G' for w :

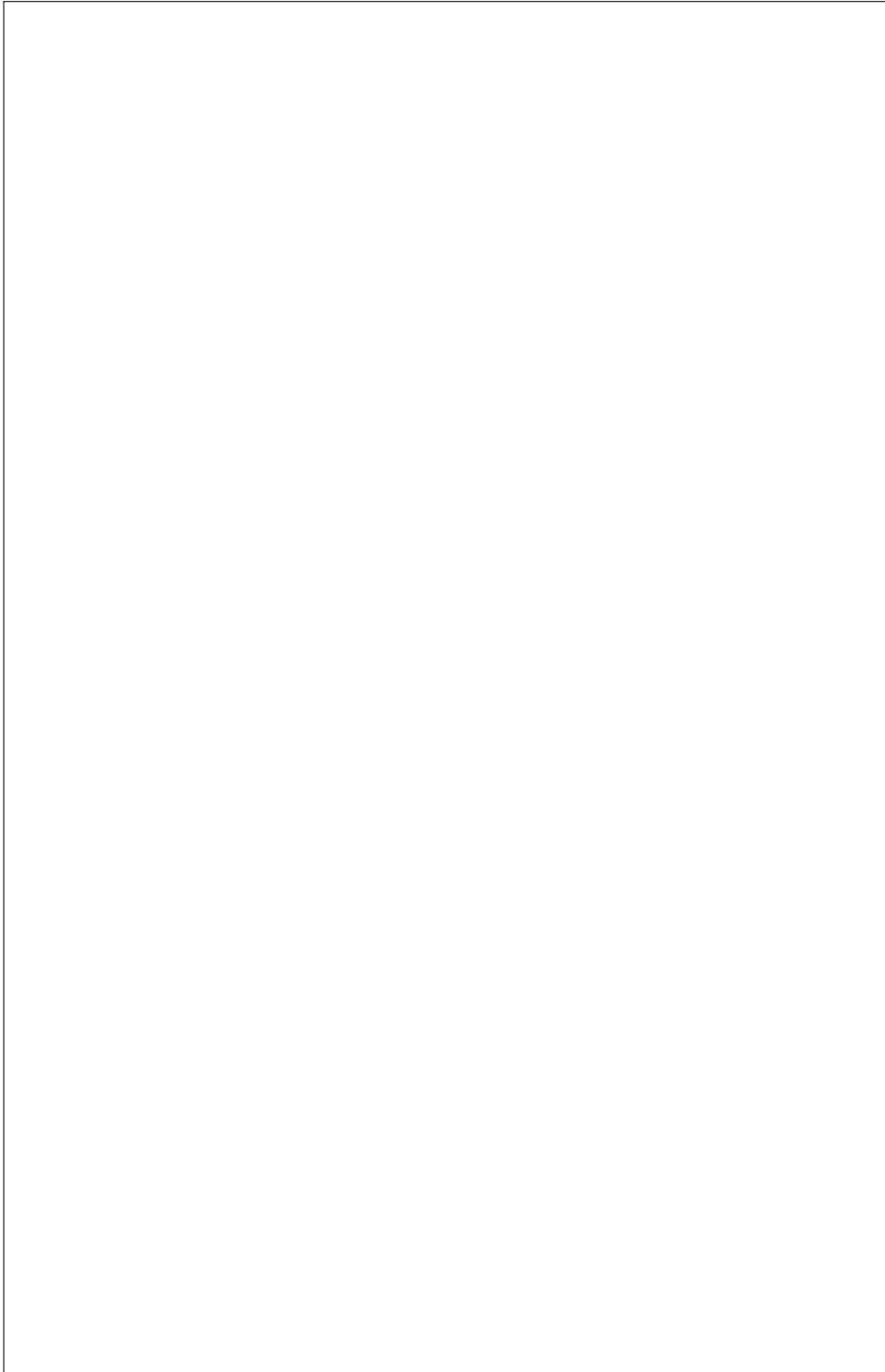

Name: _____

Student number: _____

5. (8 points) Consider the context-free language $L = \{a^{2^i} b^{i+1} \mid i > 0\}$.

(a) Give a context-free grammar G in Greibach Normal form for L .

(b) Consider the following incomplete non-extended, deterministic PDA.

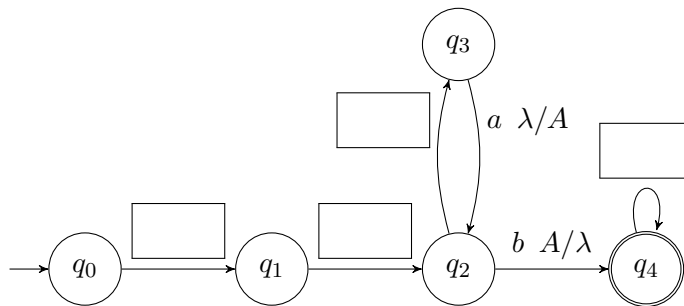

Complete the automaton such that it accepts L by filling the four white boxes. Note that we require this to be a deterministic, non-extended PDA. Only the symbol A may be pushed on the stack.

Name:

Student number:

6. (5 points) Prove or disprove: the language $L := \{a^i b^i c^i \mid i = |w| \text{ for some } w \in \mathcal{L}(a^*(ba)^*b)\}$ is context-free.

7. (6 points) Consider the language L over the alphabet $\Sigma = \{0, 1, \#\}$ with

$$L := \{1^i \# w \mid w \in \{0, 1\}^* \text{ and } \text{val}(w) = i\}$$

where $\text{val}(w)$ is the value of w interpreted as a binary number. Thus, for instance $\text{val}(1101) = 1 \cdot 2^3 + 1 \cdot 2^2 + 0 \cdot 2^1 + 1 \cdot 2^0 = 13$. We have for instance

- $11111\#101 \in L$
- $11111\#101\# \notin L$
- $\#000 \in L$
- $11\#111 \notin L$
- $1111111111111\#1101 \in L$
- $\# \in L$

Consider the following incomplete Turing machine to decide this language.

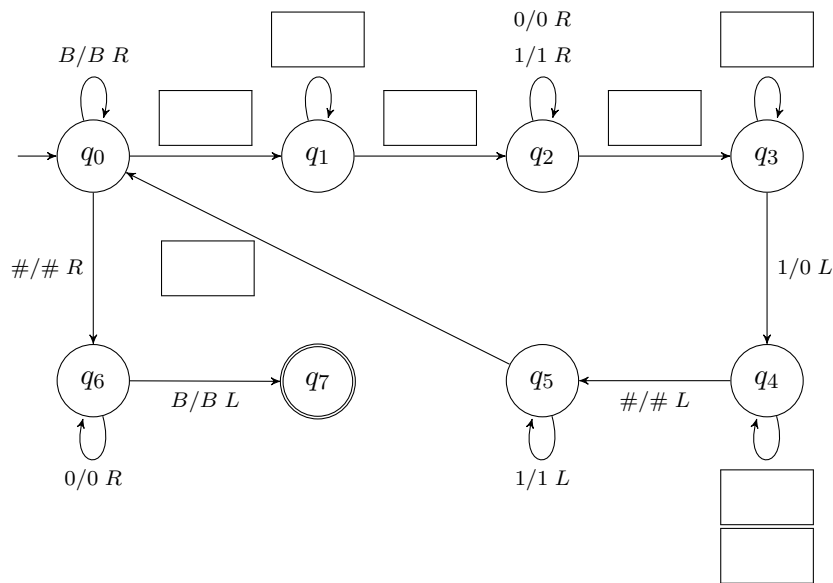

- (a) Fill in the white boxes in the automaton figure.
 (b) Decide what the following states do. Choose from the list of provided options

- state q_1 :
- state q_2 :
- state q_4 :
- state q_5 :

Possible options:

- i Search $\#$ marking the left end of w .
- ii Move from left to right over sequence of 1's. Once $\#$ is seen, move to next phase.
- iii Check whether we only have only 0's in the w part. If yes, we can accept.
- iv Accept.
- v Decrement number w by repeatedly replacing 0's by 1's until the first 1 seen can be replaced by 0.
- vi Read over blank character at the beginning of the tape. Erase the first 1 seen. If we see $\#$ instead, prepare to check whether we can accept.
- vii Search blank character left of the sequence of 1's.
- viii Move over 0's and 1's. Once a blank character is seen, move to next phase.

Name:

Student number:

Notes:

Name:

Student number:

Notes:

Name:

Student number:

Notes:

Name:

Student number:

Notes:

Name:

Student number:

Notes: